



Dragonchip

DC6388FD ISP programming interface

AppNote205

Document Revision 1.1

January, 2020

Table of Content

| | | |
|----------|----------------------------------|-----------|
| 1 | INTRODUCTION | 3 |
| 2 | HARDWARE | 4 |
| 3 | DC6688SLP-USB REV3.1..... | 7 |
| 4 | DC6688SLP-USB REV3.2..... | 9 |
| | 4.1 SINGLE DEVICE MODE | 9 |
| | 4.2 MULTIPLE DEVICES MODE | 10 |
| 5 | DCT-SLP REV3.3 | 11 |
| | 5.1 SINGLE DEVICE MODE | 11 |
| | 5.2 MULTIPLE DEVICE MODE | 12 |
| | REVISION HISTORY..... | 14 |

1 Introduction

This document describes how to do programming for DC6388FD.

2 Hardware

To do programming, 3 or 4 pads are required on PCB to complete this process, and the pins are highlighted in red.

(LQFP48)

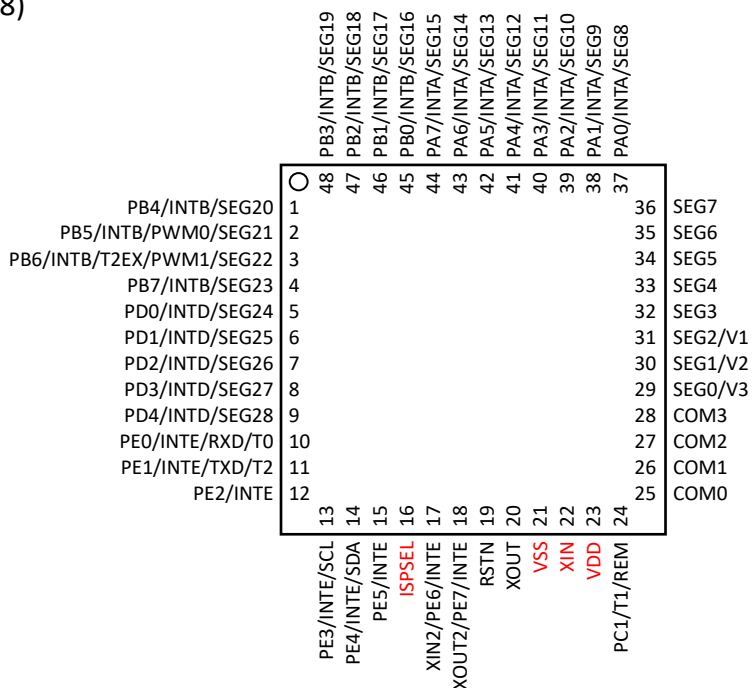

(LQFP52)

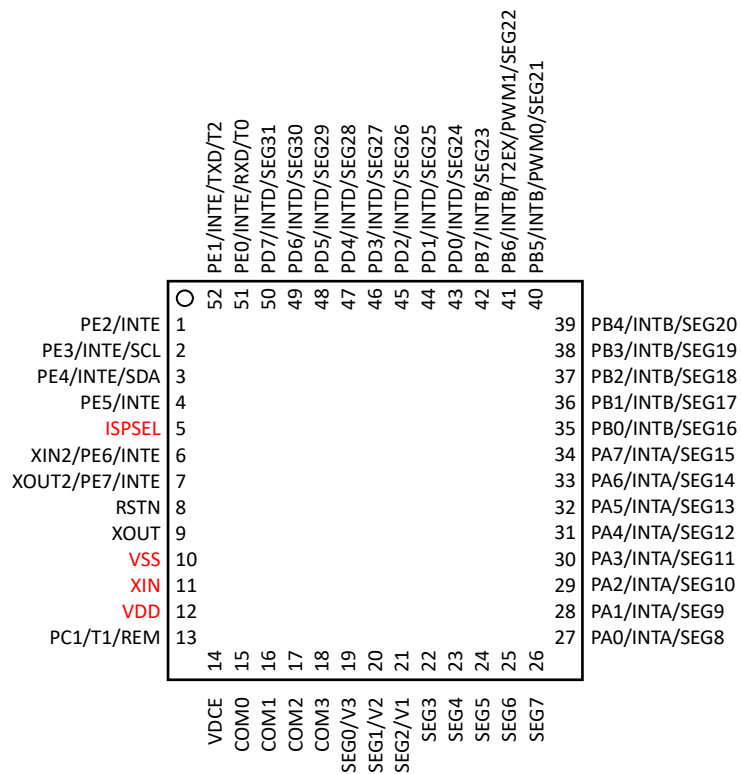

(LQFP64)

| Pin | Function | Pin | Function |
|-----|--------------------------|-----|----------------|
| 1 | PB5/INTB/PWM0/SEG29 | 17 | PE2/INTE |
| 2 | PB6/INTB/T2EX/PWM1/SEG30 | 18 | PE3/INTE/SCL |
| 3 | PB7/INTB/SEG31 | 19 | PE4/INTE/SDA |
| 4 | PD0/INTD/SEG32 | 20 | PE5/INTE |
| 5 | PD1/INTD/SEG33 | 21 | ISPSEL |
| 6 | PD2/INTD/SEG34 | 22 | XIN2/PE6/INTE |
| 7 | PD3/INTD/SEG35 | 23 | XOUT2/PE7/INTE |
| 8 | PD4/INTD/SEG36 | 24 | RSTN |
| 9 | PD5/INTD/SEG37 | 25 | XOUT |
| 10 | PD6/INTD/SEG38 | 26 | VSS |
| 11 | PD7/INTD/SEG39 | 27 | XIN |
| 12 | PC0/INTC | 28 | VDD |
| 13 | PC2/INTC | 29 | PC1/T1/REM |
| 14 | PC3/INTC | 30 | VDCE |
| 15 | PE0/INTE/RXD/T0 | 31 | COM0 |
| 16 | PE1/INTE/TXD/T2 | 32 | COM1 |
| 64 | PB4/INTB/SEG28 | 48 | SEG12 |
| 63 | PB3/INTB/SEG27 | 47 | SEG11 |
| 62 | PB2/INTB/SEG26 | 46 | SEG10 |
| 61 | PB1/INTB/SEG25 | 45 | SEG9 |
| 60 | PB0/INTB/SEG24 | 44 | SEG8 |
| 59 | PA7/INTA/SEG23 | 43 | SEG7 |
| 58 | PA6/INTA/SEG22 | 42 | SEG6/V1 |
| 57 | PA5/INTA/SEG21 | 41 | SEG5/V2 |
| 56 | PA4/INTA/SEG20 | 40 | SEG4/V3 |
| 55 | PA3/INTA/SEG19 | 39 | V4 |
| 54 | PA2/INTA/SEG18 | 38 | SEG3/COM7 |
| 53 | PA1/INTA/SEG17 | 37 | SEG2/COM6 |
| 52 | PA0/INTA/SEG16 | 36 | SEG1/COM5 |
| 51 | SEG15 | 35 | SEG0/COM4 |
| 50 | SEG14 | 34 | COM3 |
| 49 | SEG13 | 33 | COM2 |

The programmer requires any one of below:

1. DC6688SLP-USB Rev3.1/3.2.
2. DCT-SLP Rev3.3

The programmer can be able to program up to 10 devices (Device 1 ~ 10).

3 DC6688SLP-USB Rev3.1

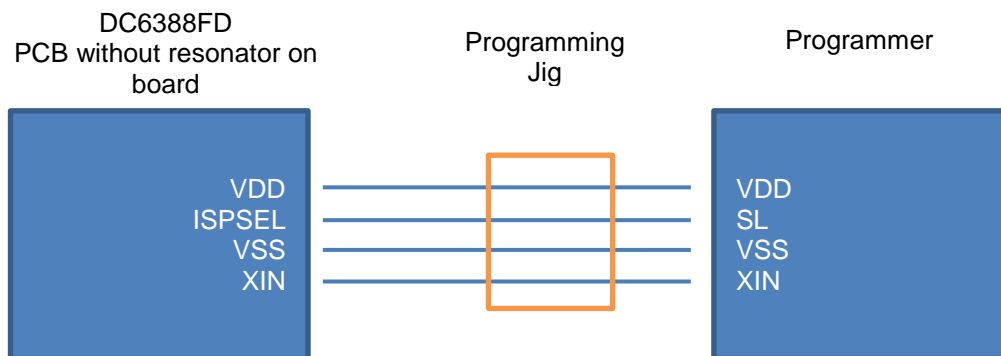
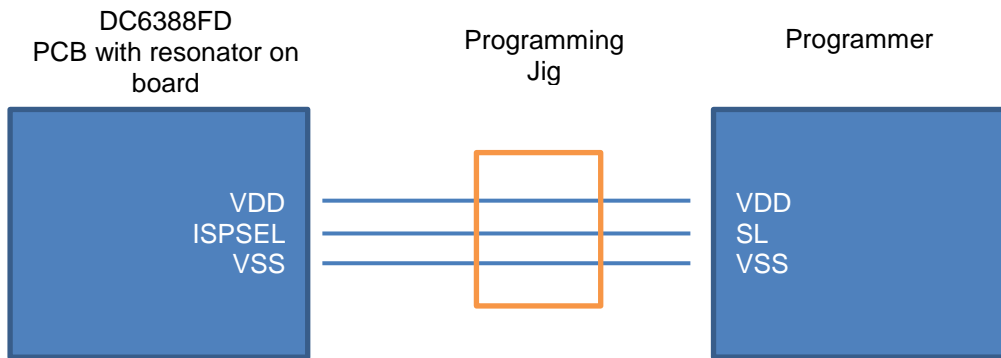

SLP Rev3.1

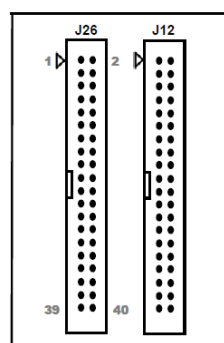

J26 Pin Assignment

| Pin | Name | Connection | Pin | Name | Connection |
|-----|-------|--------------------|-----|------|------------|
| 1 | NC | - | 2 | GND | GND |
| 3 | NC | - | 4 | NC | - |
| 5 | NC | - | 6 | NC | - |
| 7 | NC | - | 8 | NC | - |
| 9 | NC | - | 10 | NC | - |
| 11 | NC | - | 12 | NC | - |
| 13 | NC | - | 14 | NC | - |
| 15 | NC | - | 16 | NC | - |
| 17 | NC | - | 18 | GND | GND |
| 19 | GND | GND | 20 | NC | - |
| 21 | XIN1 | D1 XIN / XIN2 pin | 22 | GND | GND |
| 23 | XIN2 | D2 XIN / XIN2 pin | 24 | GND | GND |
| 25 | XIN3 | D3 XIN / XIN2 pin | 26 | GND | GND |
| 27 | XIN4 | D4 XIN / XIN2 pin | 28 | GND | GND |
| 29 | XIN5 | D5 XIN / XIN2 pin | 30 | GND | GND |
| 31 | XIN6 | D6 XIN / XIN2 pin | 32 | GND | GND |
| 33 | XIN7 | D7 XIN / XIN2 pin | 34 | GND | GND |
| 35 | XIN8 | D8 XIN / XIN2 pin | 36 | GND | GND |
| 37 | XIN9 | D9 XIN / XIN2 pin | 38 | GND | GND |
| 39 | XIN10 | D10 XIN / XIN2 pin | 40 | GND | GND |

Each XIN pin for 1 IC's XIN

VDD / SL / VSS pins connection is shown below.

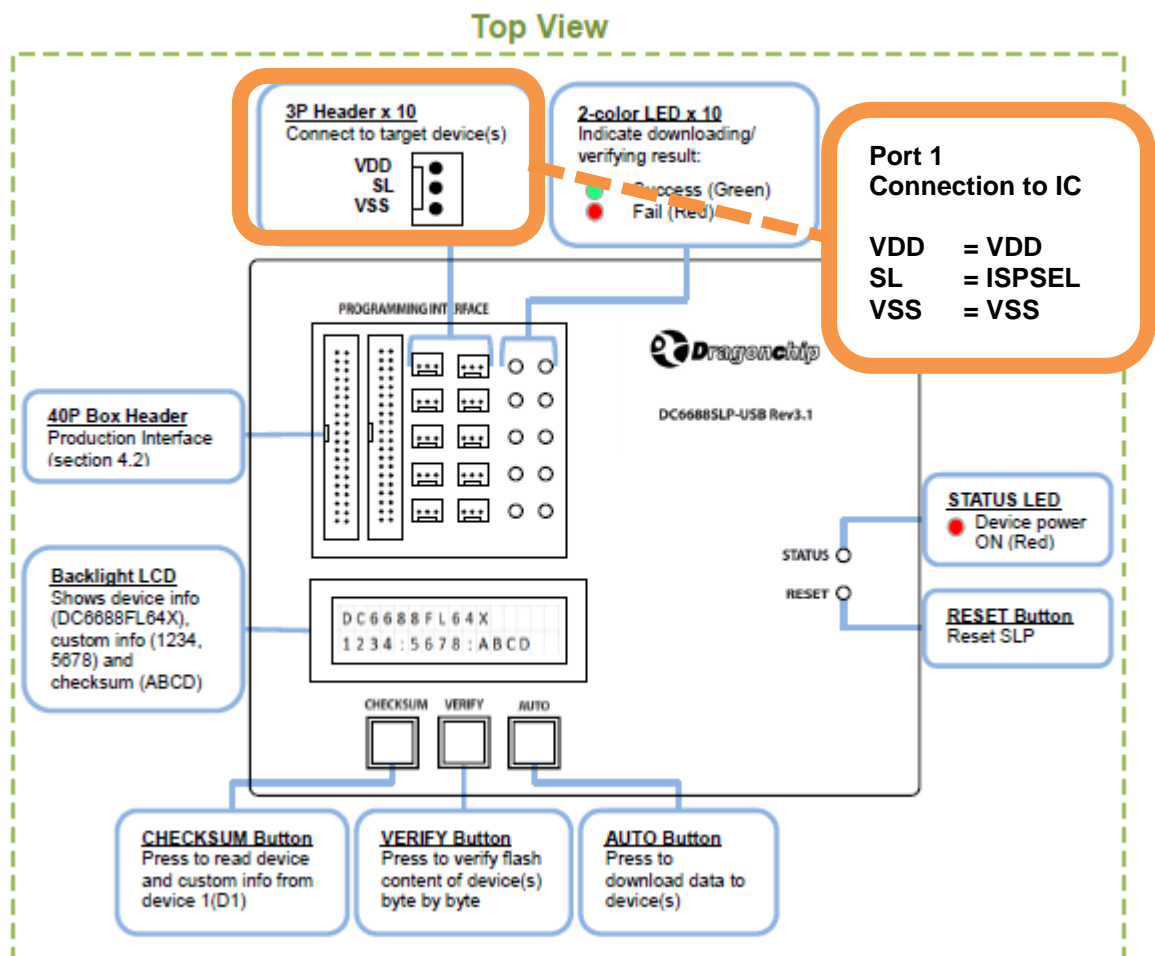

4 DC6688SLP-USB Rev3.2

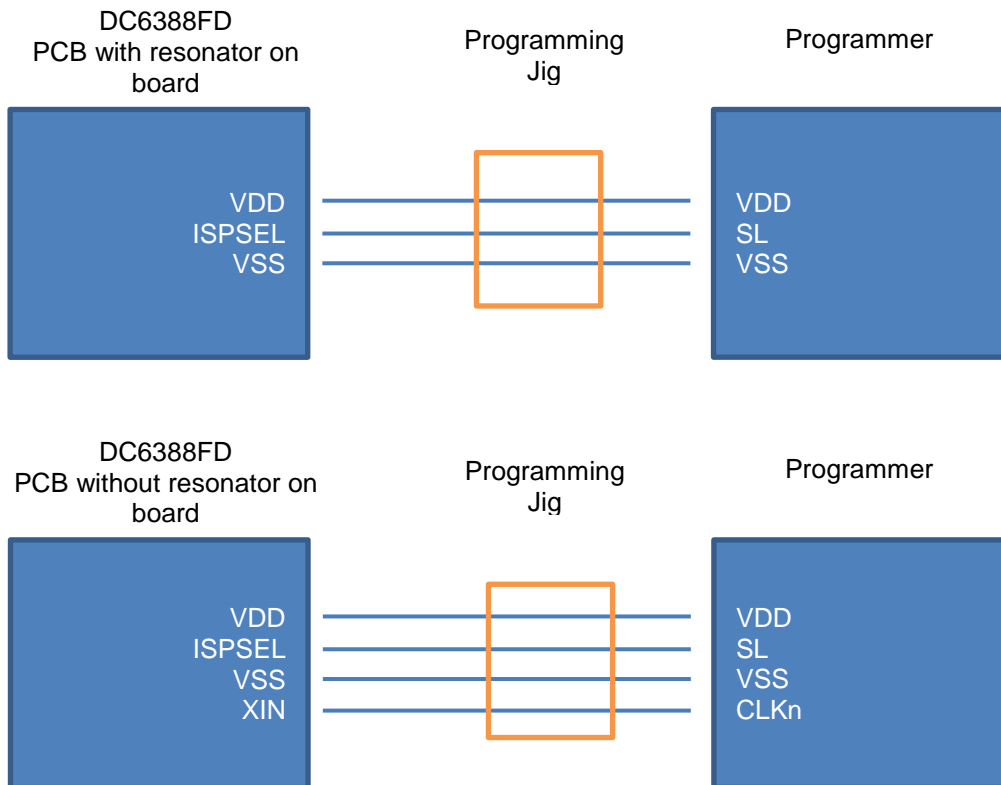

4.1 Single Device Mode

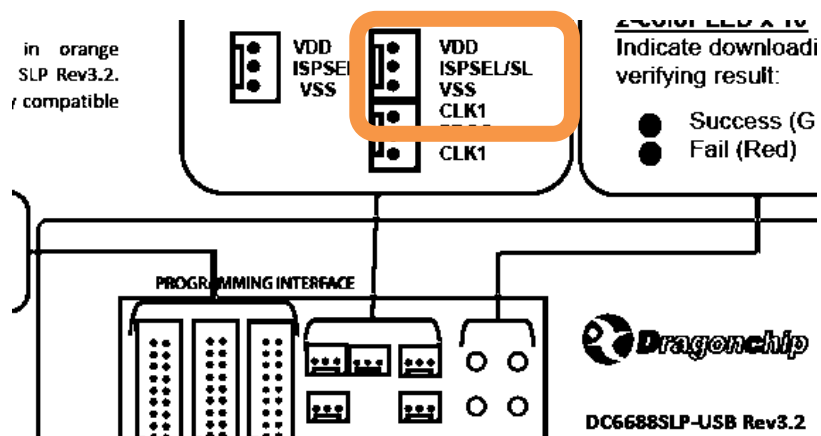

4.2 Multiple Devices Mode

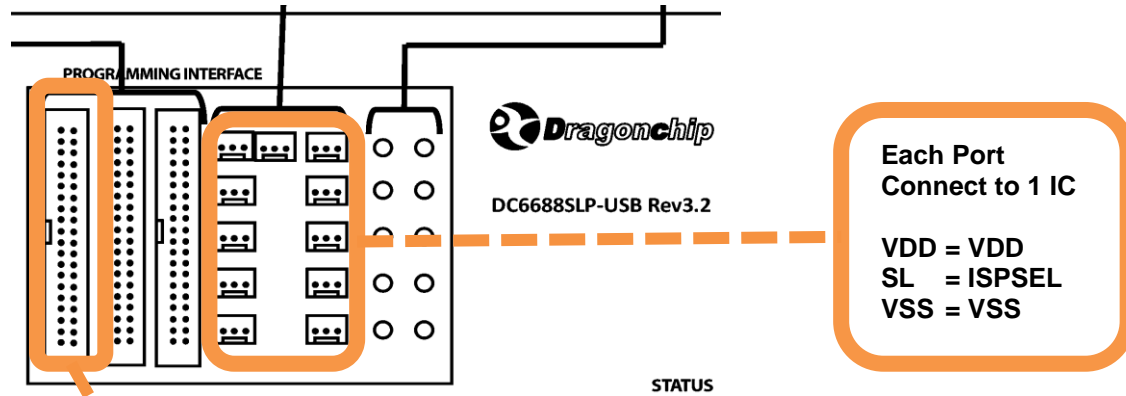

J26 Pin Assignment

| Pin | Name | Connection | Pin | Name |
|-----|--------|------------------------|-----|---------|
| 1 | LCD_P9 | LCD module pin 9 (DB2) | 2 | GND |
| 3 | LCD_P8 | LCD module pin 8 (DB1) | 4 | LCD_P10 |
| 5 | LCD_P7 | LCD module pin 7 (DB0) | 6 | LCD_P11 |
| 7 | LCD_P6 | LCD module pin 6 (E) | 8 | LCD_P12 |
| 9 | LCD_P5 | LCD module pin 5 (R/W) | 10 | LCD_P13 |
| 11 | LCD_P4 | LCD module pin 4 (RS) | 12 | LCD_P14 |
| 13 | LCD_P3 | LCD module pin 3 (VEE) | 14 | LCD_P15 |
| 15 | LCD_P2 | LCD module pin 2 (VCC) | 16 | LCD_P16 |
| 17 | LCD_P1 | LCD module pin 1 (VSS) | 18 | GND |
| 19 | GND | GND | 20 | NC |
| 21 | CLK1 | D1 XIN/ ECLK pin | 22 | GND |
| 23 | CLK2 | D2 XIN/ ECLK pin | 24 | GND |
| 25 | CLK3 | D3 XIN/ ECLK pin | 26 | GND |
| 27 | CLK4 | D4 XIN/ ECLK pin | 28 | GND |
| 29 | CLK5 | D5 XIN/ ECLK pin | 30 | GND |
| 31 | CLK6 | D6 XIN/ ECLK pin | 32 | GND |
| 33 | CLK7 | D7 XIN/ ECLK pin | 34 | GND |
| 35 | CLK8 | D8 XIN/ ECLK pin | 36 | GND |
| 37 | CLK9 | D9 XIN/ ECLK pin | 38 | GND |
| 39 | CLK10 | D10 XIN/ ECLK pin | 40 | GND |

Each CLK pin for 1 IC's XIN

5 DCT-SLP Rev3.3

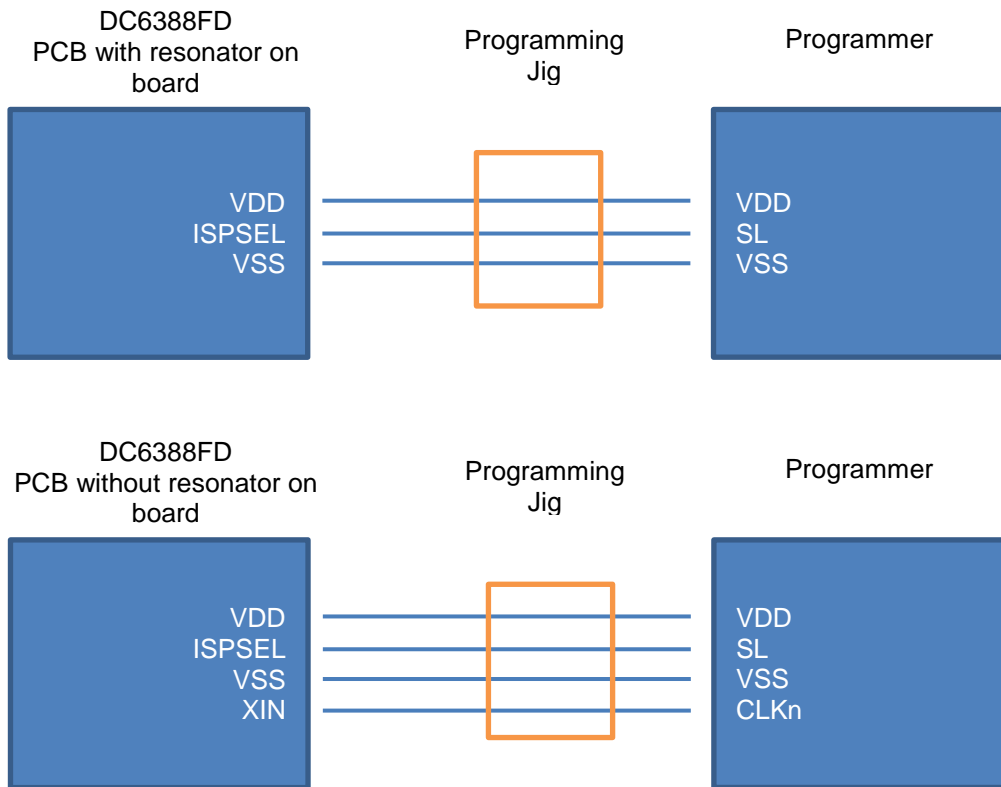

5.1 Single Device Mode

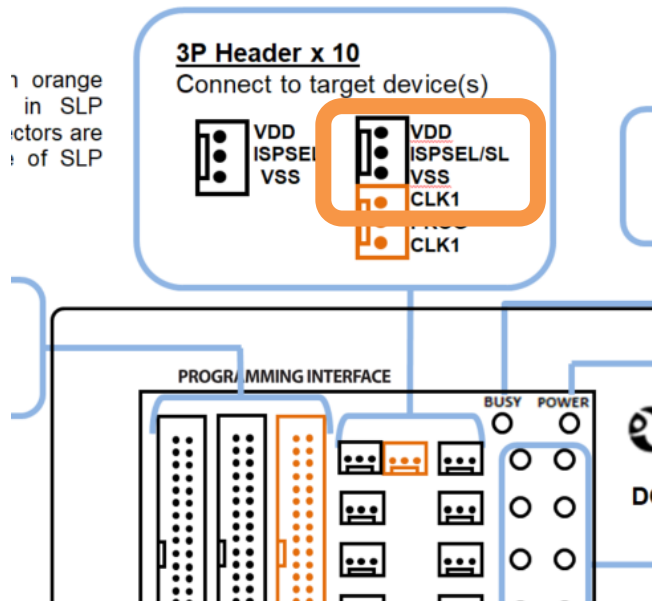

5.2 Multiple Device Mode

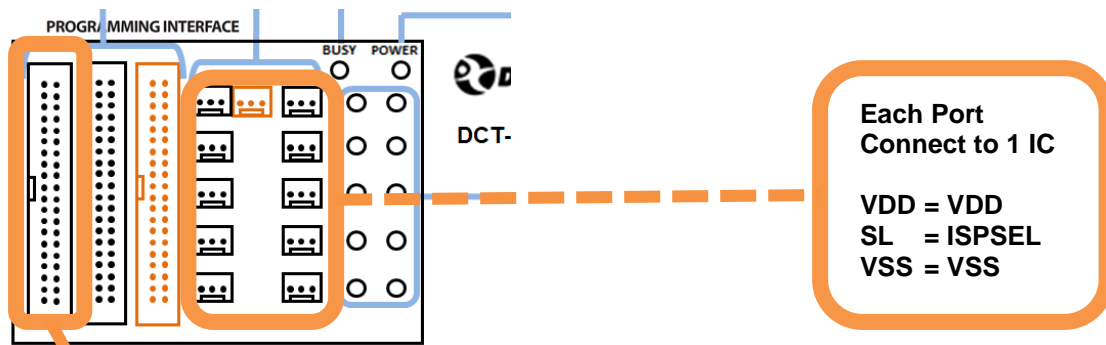

J26 Pin Assignment

| Pin | Name | Connection | Pin | Name |
|-----|--------|------------------------|-----|---------|
| 1 | LCD_P9 | LCD module pin 9 (DB2) | 2 | GND |
| 3 | LCD_P8 | LCD module pin 8 (DB1) | 4 | LCD_P10 |
| 5 | LCD_P7 | LCD module pin 7 (DB0) | 6 | LCD_P11 |
| 7 | LCD_P6 | LCD module pin 6 (E) | 8 | LCD_P12 |
| 9 | LCD_P5 | LCD module pin 5 (R/W) | 10 | LCD_P13 |
| 11 | LCD_P4 | LCD module pin 4 (RS) | 12 | LCD_P14 |
| 13 | LCD_P3 | LCD module pin 3 (VEE) | 14 | LCD_P15 |
| 15 | LCD_P2 | LCD module pin 2 (VCC) | 16 | LCD_P16 |
| 17 | LCD_P1 | LCD module pin 1 (VSS) | 18 | GND |
| 19 | GND | GND | 20 | NC |
| 21 | CLK1 | D1 XIN/ ECLK pin | 22 | GND |
| 23 | CLK2 | D2 XIN/ ECLK pin | 24 | GND |
| 25 | CLK3 | D3 XIN/ ECLK pin | 26 | GND |
| 27 | CLK4 | D4 XIN/ ECLK pin | 28 | GND |
| 29 | CLK5 | D5 XIN/ ECLK pin | 30 | GND |
| 31 | CLK6 | D6 XIN/ ECLK pin | 32 | GND |
| 33 | CLK7 | D7 XIN/ ECLK pin | 34 | GND |
| 35 | CLK8 | D8 XIN/ ECLK pin | 36 | GND |
| 37 | CLK9 | D9 XIN/ ECLK pin | 38 | GND |
| 39 | CLK10 | D10 XIN/ ECLK pin | 40 | GND |

Each CLK pin for 1 IC's XIN

Revision History

| Document Rev. No. | Issued Date | Section | Page | Description | Edited By | Reviewed By |
|-------------------|-------------|---------|------|----------------------|-----------|-------------|
| 1.0 | Aug, 2018 | | | First release | Danny Ho | Patrick Li |
| 1.1 | Jan, 2020 | 5 | | Added DCT-SLP Rev3.3 | Danny Ho | Patrick Li |
| | | | | | | |

Copyright Notice

This specification is copyrighted by Dragonchip Ltd. No part of this specification may be reproduced in any form or means, without the expressed written consent Dragonchip Ltd.

Disclaimer

Dragonchip Ltd. assumes no responsibility for any errors contained herein.

Copyright by Dragonchip Ltd. All Rights Reserved.
Dragonchip Ltd.
TEL: (852) 2776-0111
FAX: (852) 2776-0996
<http://www.dragonchip.com>