



Dragonchip

DC6688F2STR / F2STK / F2SPN ISP programming interface

AppNote092

Document Revision 1.3

January, 2020

Table of Content

1	INTRODUCTION	3
2	HARDWARE.....	4
3	DC6688SLP-USB REV3.1.....	6
4	DC6688SLP-USB REV3.2.....	8
	4.1 SINGLE DEVICE MODE	8
	4.2 MULTIPLE DEVICE MODE.....	8
5	DCT-SLP REV3.3	10
	5.1 SINGLE DEVICE MODE	10
	5.2 MULTIPLE DEVICE MODE.....	10
	REVISION HISTORY	12

1 Introduction

This document describes how to connect DC6688F2STR / DC6688F2STK / DC6688F2SPN with programmer.

2 Hardware

To do trimming during programming stage, 4 pads are required on PCB to complete this process, and the pins are highlighted in red.

DC6688F2STR TSSOP16 and DC6688F2STK

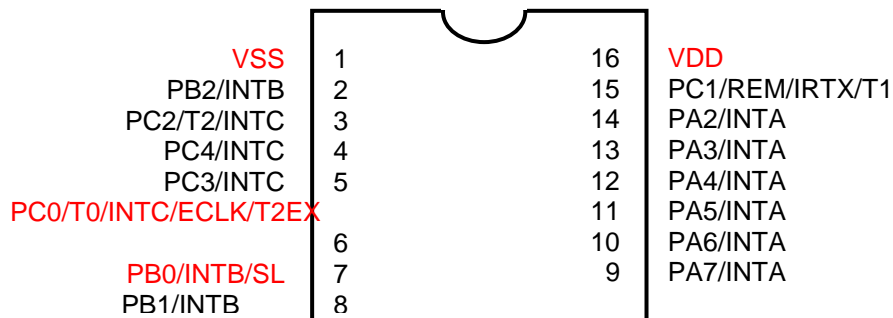

DC6688F2STR TSSOP20

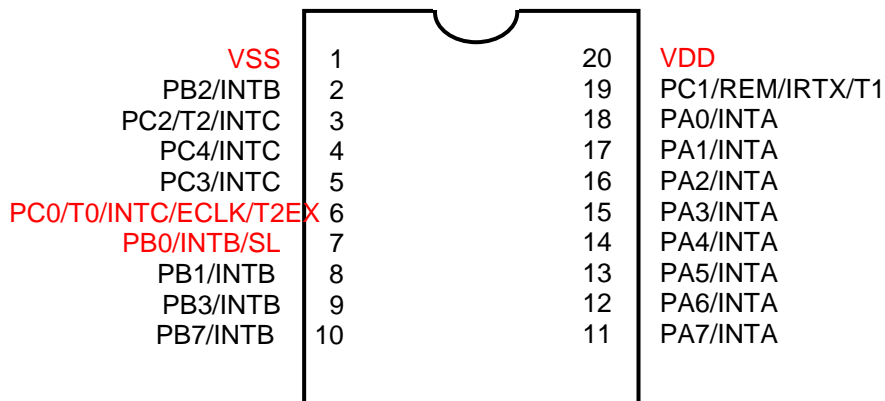

DC6688F2SPN TSSOP20

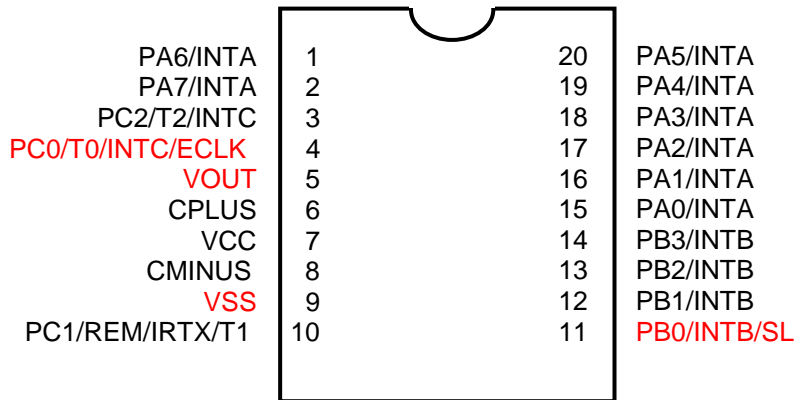

The programmer requires any one of below:

1. DC6688SLP-USB Rev3.1/3.2.
2. DCT-SLP Rev3.3

Item 1 and 2 above can be able to program up to 8 devices (Device 1 ~ 8).
The pin assignment on the programmer is shown in the following section.

3 DC6688SLP-USB Rev3.1

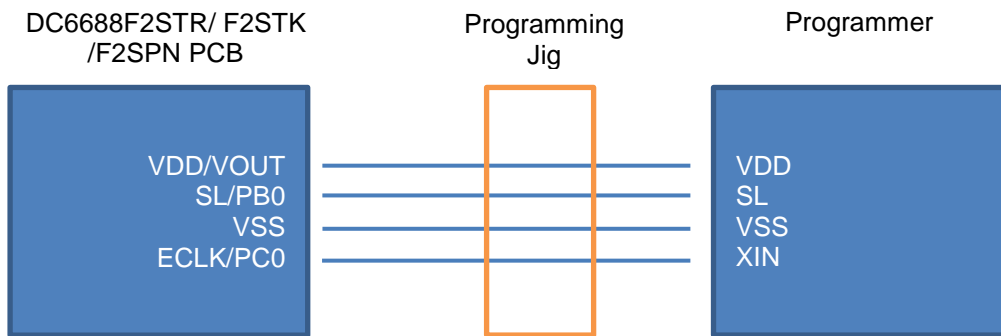

SLP Rev3.1

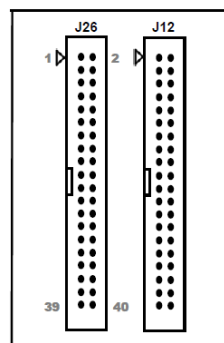

J26 Pin Assignment

Pin	Name	Connection	Pin	Name	Connection
1	NC	-	2	GND	GND
3	NC	-	4	NC	-
5	NC	-	6	NC	-
7	NC	-	8	NC	-
9	NC	-	10	NC	-
11	NC	-	12	NC	-
13	NC	-	14	NC	-
15	NC	-	16	NC	-
17	NC	-	18	GND	GND
19	GND	GND	20	NC	-
21	XIN1	D1 XIN / XIN2 pin	22	GND	GND
23	XIN2	D2 XIN / XIN2 pin	24	GND	GND
25	XIN3	D3 XIN / XIN2 pin	26	GND	GND
27	XIN4	D4 XIN / XIN2 pin	28	GND	GND
29	XIN5	D5 XIN / XIN2 pin	30	GND	GND
31	XIN6	D6 XIN / XIN2 pin	32	GND	GND
33	XIN7	D7 XIN / XIN2 pin	34	GND	GND
35	XIN8	D8 XIN / XIN2 pin	36	GND	GND
37	XIN9	D9 XIN / XIN2 pin	38	GND	GND
39	XIN10	D10 XIN / XIN2 pin	40	GND	GND

Each XIN pin for 1 IC's ECLK

VDD / SL / VSS pins connection is shown below.

Top View

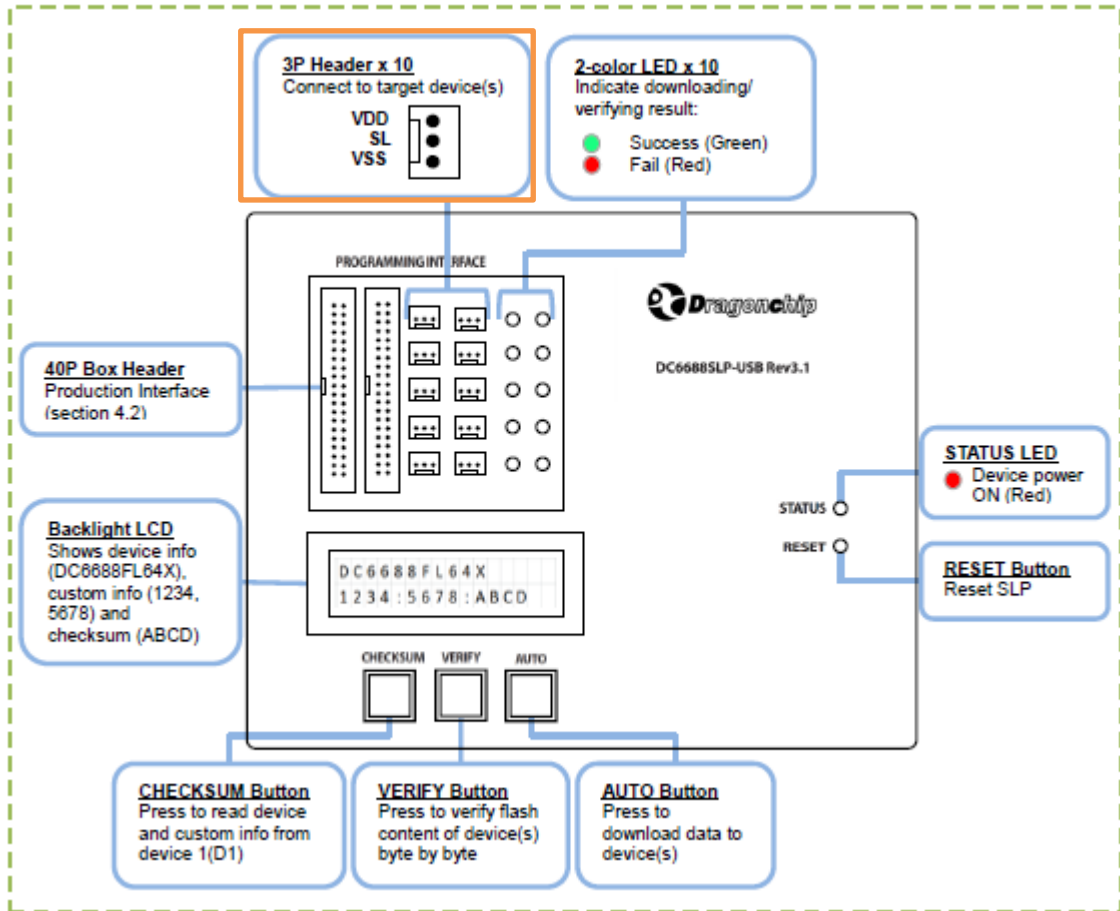

4 DC6688SLP-USB Rev3.2

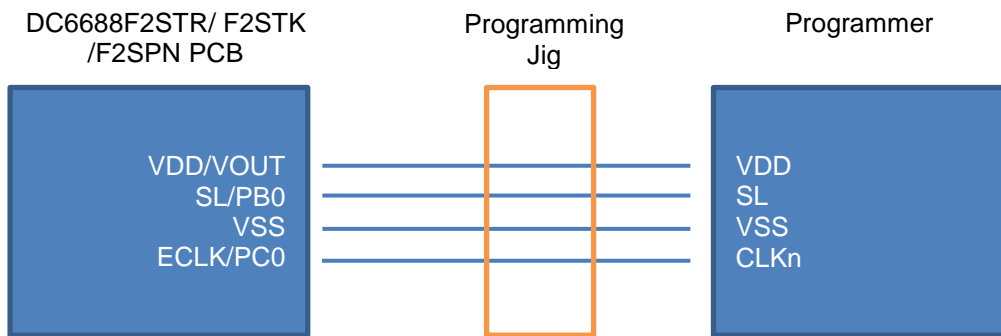

4.1 Single Device Mode

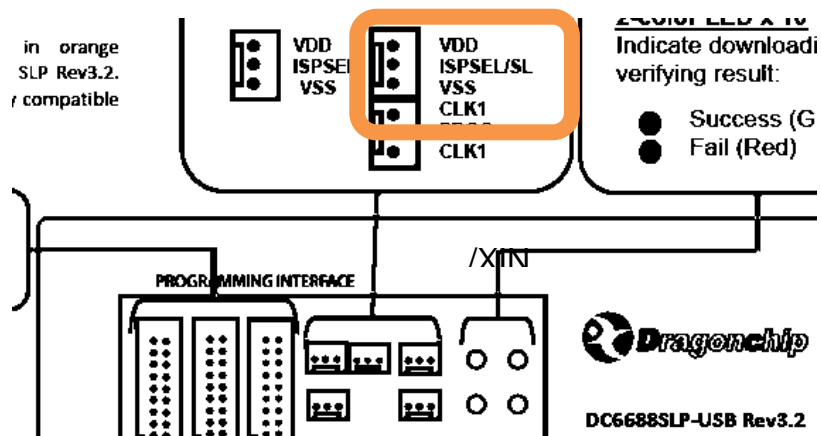

4.2 Multiple Device Mode

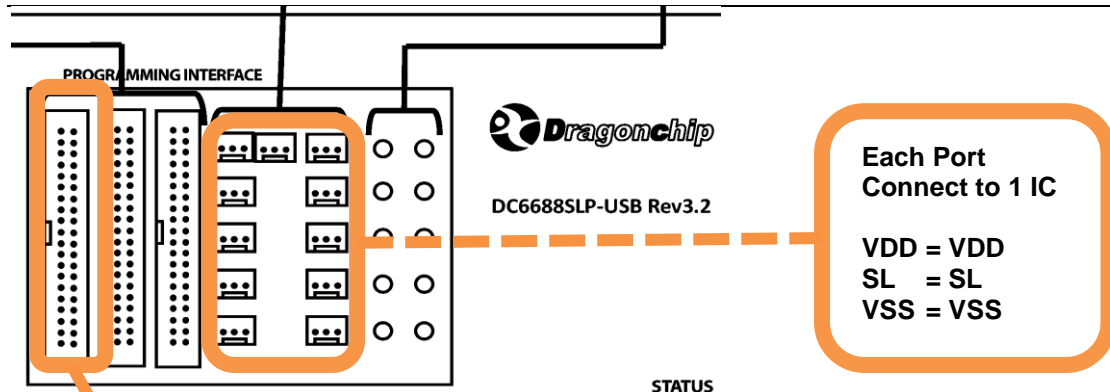

STATUS

J27 Pin Assignment

Pin	Name	Connection
1	NC	NC
2	NC	NC
3	NC	NC
4	NC	NC
5	NC	NC
6	NC	NC
7	NC	NC
8	NC	NC
9	NC	NC
10	NC	NC
11	NC	NC
12	NC	NC
13	NC	NC
14	NC	NC
15	PROG_A	PROG of D1-D5
16	PROG_B	PROG of D6-D10
17	GND	GND
18	GND	
19	GND	
20	NC	
21	GND	
22	GND	
23	GND	
24	GND	
25	GND	
26	GND	
27	GND	
28	GND	
29	GND	
30	GND	
31	GND	
32	GND	
33	GND	
34	GND	
35	GND	
36	GND	
37	GND	
38	GND	
39	GND	
40	GND	

J26 Pin Assignment

Pin	Name	Connection	Pin	Name	Connection
1	LCD_P9	LCD module pin 9 (DB2)	2	GND	
3	LCD_P8	LCD module pin 8 (DB1)	4	LCC	
5	LCD_P7	LCD module pin 7 (DB0)	6	LCC	
7	LCD_P6	LCD module pin 6 (E)	8	LCC	
9	LCD_P5	LCD module pin 5 (R/W)	10	LCC	
11	LCD_P4	LCD module pin 4 (RS)	12	LCC	
13	LCD_P3	LCD module pin 3 (VEE)	14	LCC	
15	LCD_P2	LCD module pin 2 (VCC)	16	LCC	
17	LCD_P1	LCD module pin 1 (VSS)	18	GND	
19	GND		20	NC	
21	CLK1	D1 XIN/ ECLK pin	22	GND	
23	CLK2	D2 XIN/ ECLK pin	24	GND	
25	CLK3	D3 XIN/ ECLK pin	26	GND	
27	CLK4	D4 XIN/ ECLK pin	28	GND	
29	CLK5	D5 XIN/ ECLK pin	30	GND	
31	CLK6	D6 XIN/ ECLK pin	32	GND	
33	CLK7	D7 XIN/ ECLK pin	34	GND	
35	CLK8	D8 XIN/ ECLK pin	36	GND	
37	CLK9	D9 XIN/ ECLK pin	38	GND	
39	CLK10	D10 XIN/ ECLK pin	40	GND	

Each XIN pin for 1 IC's ECLK

5 DCT-SLP Rev3.3

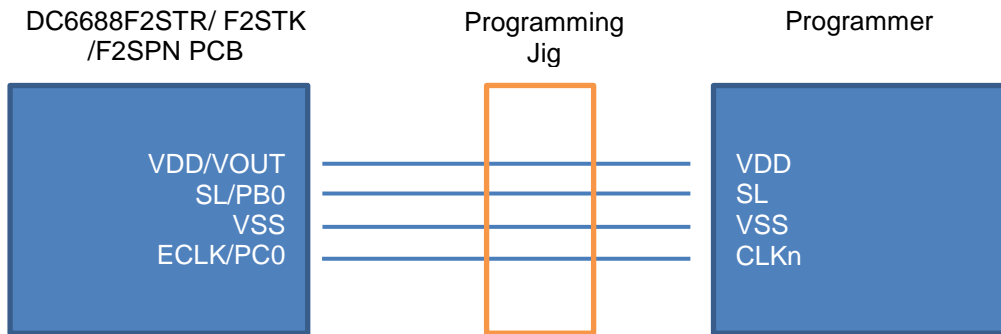

5.1 Single Device Mode

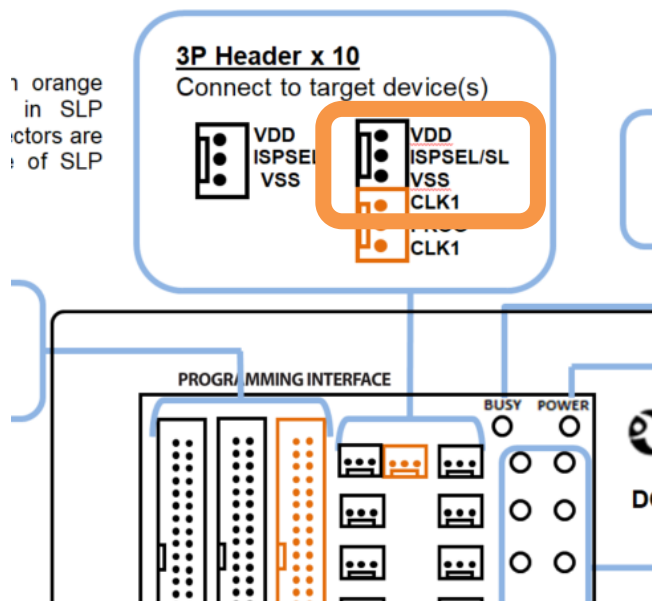

5.2 Multiple Device Mode

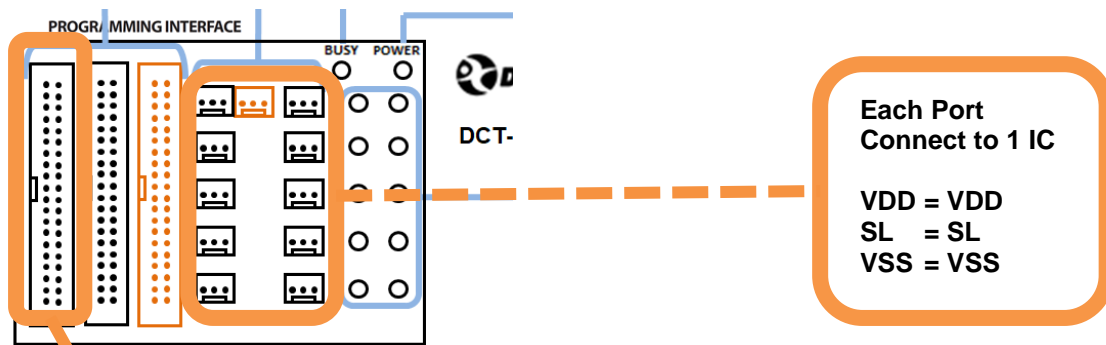

J26 Pin Assignment

Pin	Name	Connection
1	LCD_P9	LCD module pin 9 (DB2)
3	LCD_P8	LCD module pin 8 (DB1)
5	LCD_P7	LCD module pin 7 (DB0)
7	LCD_P6	LCD module pin 6 (E)
9	LCD_P5	LCD module pin 5 (R/W)
11	LCD_P4	LCD module pin 4 (RS)
13	LCD_P3	LCD module pin 3 (VEE)
15	LCD_P2	LCD module pin 2 (VCC)
17	LCD_P1	LCD module pin 1 (VSS)
19	GND	GND
21	CLK1	D1 XIN/ ECLK pin
23	CLK2	D2 XIN/ ECLK pin
25	CLK3	D3 XIN/ ECLK pin
27	CLK4	D4 XIN/ ECLK pin
29	CLK5	D5 XIN/ ECLK pin
31	CLK6	D6 XIN/ ECLK pin
33	CLK7	D7 XIN/ ECLK pin
35	CLK8	D8 XIN/ ECLK pin
37	CLK9	D9 XIN/ ECLK pin
39	CLK10	D10 XIN/ ECLK pin

Each XIN pin for 1 IC's ECLK

J27 Pin Assignment

Pin	Name	Connection
1	NC	NC
3	NC	NC
5	NC	NC
7	NC	NC
9	NC	NC
11	NC	NC
13	NC	NC
15	PROG_A	PROG of D1-D5
17	PROG_B	PROG of D6-D10
19	GND	GND
20	NC	
22	GND	
24	GND	
26	GND	
28	GND	
30	GND	
32	GND	
34	GND	
36	GND	
38	GND	
40	GND	

Revision History

Document Rev. No.	Issued Date	Section	Page	Description	Edited By	Reviewed By
1.0	Nov, 2014			First release	Philip Hung	Danny Ho
1.1	Oct 2015			Include DC6688SLP-USB Rev3.2	Danny Ho	Celia Ki
1.2	Dec, 2017			Update cover page	Danny Ho	Patrick Li
1.3	Jan, 2020			Added DCT-SLP Rev3.3	Danny Ho	Patrick Li

Copyright Notice

This specification is copyrighted by Dragonchip Ltd. No part of this specification may be reproduced in any form or means, without the expressed written consent Dragonchip Ltd.

Disclaimer

Dragonchip Ltd. assumes no responsibility for any errors contained herein.

Copyright by Dragonchip Ltd. All Rights Reserved.
Dragonchip Ltd.
TEL: (852) 2776-0111
FAX: (852) 2776-0996
<http://www.dragonchip.com>